

# ACCESSIBILITY KIT-A1 INSTALLATION PROCEDURE

Follow the instructions in this booklet when installing the kit to its host machine.

**E N G L I S H**

# ACCESSIBILITY KIT-A1 INSTALLATION PROCEDURE

## 1 | Checking the Contents

Open the cardboard box, and check to make sure that none of the items listed below is missing.

### iR5000/iR6000

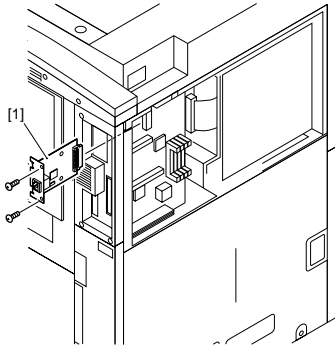

### iR8500/iR7200/iR105

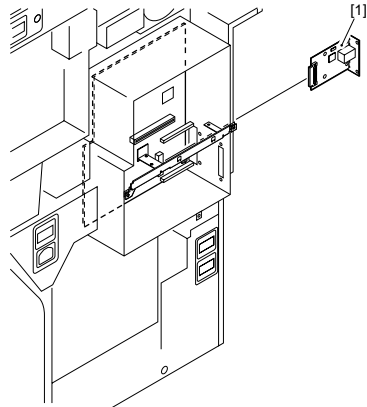

### iR2200/iR2800/iR3300

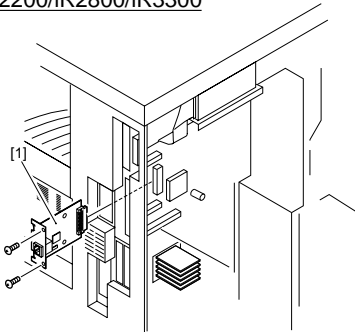

- [1] Network PCB ..... 1 pc.
- [2] User Manual CD-ROM ..... 1 pc.
- [3] CD-ROM Explanation Sheet ..... 1 pc.
- [4] Remote UI Guide ..... 1 pc.

Fig.1-1

### **⚠ Caution:**

Take note of the following to avoid damaging the PCBs by static charges:

1. Put on a grounded wrist strap before starting the work. If no grounding terminal is found, use the frame of the main body.
2. Keep each PCB in an anti-static bag until immediately before it is used.
3. When you handle a PCB, be sure to hold the frame of the PCB (i.e., base material area) without touching terminals.
4. If you must place a PCB temporarily, be sure that the area is treated against static charges (e.g., anti-static mat). Otherwise, place it on or in an anti-static bag. Do not place it on a metal plate.
5. Be sure not to leave insulators which are subject to being charged in the work area.

## 2 Checking Operating Conditions

Verify that the main controller software (MN-CONT) and the remote UI (RUI) are of the versions specified below or later.

To check the version of MN-CONT or RUI, enter service mode and go to COPIER> DISPLAY> VERSION> MN-CONT or RUI. If either program is older than the specified version below, it has to be upgraded.

	<u>MN-CONT</u>	<u>RUI</u>
iR5000/iR6000	: 50.05	40.06
iR2200/iR2800/iR3300	: 21.02	21.01
iR8500	: 20.14	20.13
iR7200	: 32.01	20.13
iR105	: 20.13	20.13

## 3 Installation

### iR5000/iR6000

1. Turn off the main power switch.
2. Remove the two screws [1], and detach the blank plate 1 [2].

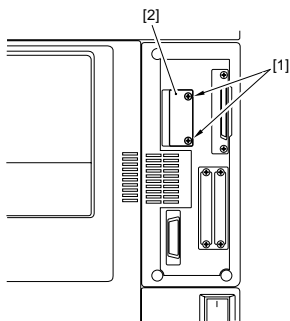

Fig.2-1

3. Insert the network PCB [1] into the slot. Then, secure the network PCB in place with the two screws [2] initially used to keep the blank plate in place.



Check to make sure that the connector is securely fitted.

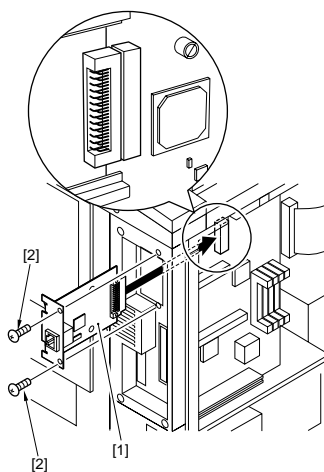

Fig.2-2

### iR2200/iR2800/iR3300

1. Turn off the main power switch.
2. Remove the two screws [1], and detach the blank plate 1 [2].

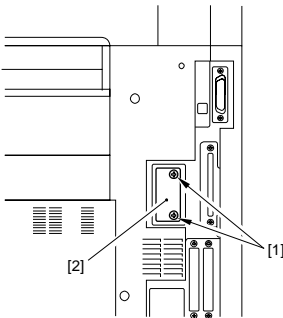

Fig.2-3

3. Insert the network PCB [1] into the slot. Then, secure the network PCB in place with the two screws [2] initially used to keep the blank plate in place.



Check to make sure that the connector is securely fitted.

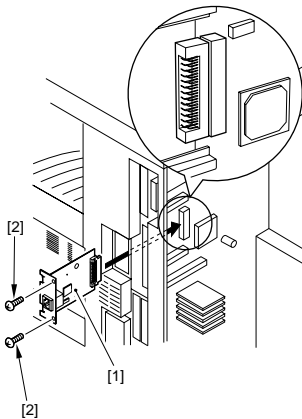

Fig.2-4

### iR8500/iR7200/iR105

1. Turn off the main power switch.
2. Remove the following screws [1], and remove the rear cover [2].

a. iR8500/iR7200: 10 screws



In case of iR7200, remove the rear upper cover [3] by detaching the 4screws before removing the rear cover.

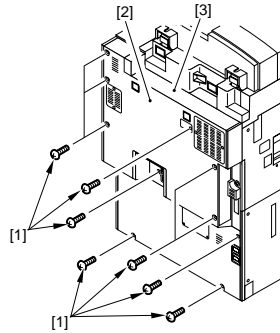

Fig.2-5

b. iR105: 11 screws

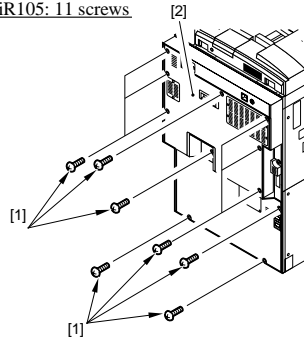

Fig.2-6

3. Remove the interface cable [1].

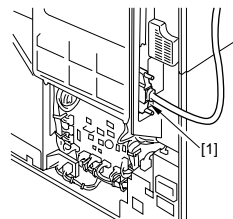
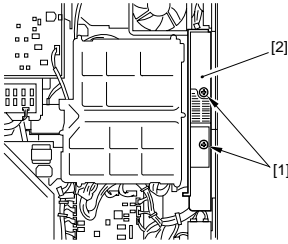

Fig.2-7

- Remove the screws [1] (2), and remove the rear right cover [2].



**Fig.2-8**

- Remove the screws [1] (2), and remove the blanking plate 1 [2].

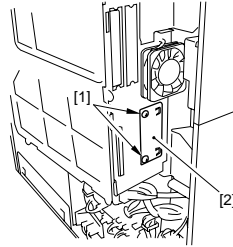

**Fig.2-10**

- Remove the screws [1] (4), and pull the main controller box [2] out.

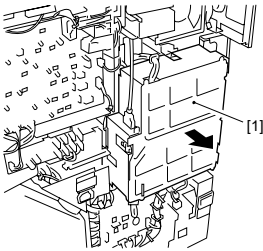
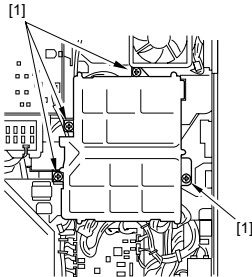
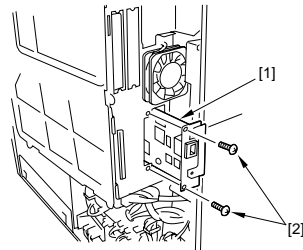

**Fig.2-9**

- Fix the network PCB [1] with the screws for attaching the blanking plate 1 [2] (2).



Make sure that the connector is inserted properly.



**Fig.2-11**

- Push the main controller box (pulled out in Procedure 5) in, and fix it with screws (4).
- Attach the rear right cover removed in Procedure 4.
- Attach the interface cable removed in Procedure 3.
- Attach the rear cover removed in Procedure 2.

4	Connection To Network
---	-----------------------

1. Turn off the main power of a main unit.
2. Connect a network cable to a main unit, and turn on the main power.
3. Inform a system administrator at a user's site that the installation is done and ask him/her to do network settings.

5	Connection Check
---	------------------

In case a network environment at the user's site is TCP/IP, using the PING function, check if the installation of the network PCB and the network settings are correctly done.

In case a network environment is IPX/SPX or Apple Talk, a connection check is not necessary.

### 5.1. How To Use PING Function

1. Select PING in the service mode.  
Service mode> Copier> Test  
    > NETWORK> PING
2. Input an IP address by numeric keys on the control panel, and press "OK" key.
3. Press "START" key.
4. If PING is successfully done, "OK" is indicated. If not, "NG" is indicated.

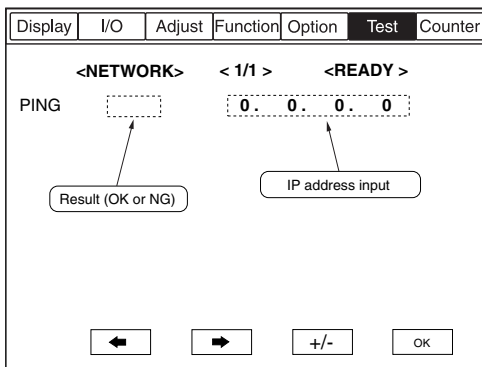

Fig.5-1

### 5.2. Check With Remote Host Address

If you execute PING with a remote host address\*, you can check whether or not the connection to the network is properly established or not.

\*Remote host address: An IP address of a PC terminal which is connected to a main unit via TCP/IP.

1. Inform a system administrator that you would like to check the network connection by using PING function.
2. Ask a system administrator a remote host address.
3. Input a remote host address to PING.
4. If "OK" is indicated, the connection to the network is properly established.
5. If "NG" is indicated, the connection to the network is not properly established.

In this case, troubleshoot in accordance with the instructions given below.

In case a connection to the network cannot be properly established, conceivable causes are as follows. Following the instructions in 5.1 through 5.3, troubleshoot a problem.

1. Connection failure between the network and the network PCB.
2. Faulty TCP/IP settings of a main unit.
3. Faulty network PCB, or PCB installation failure.
4. Faulty user network.

### 6.1. Check The Network Cable Connection

Check if the network cable is properly connected to the network PCB.

1. If it is properly connected, follow the instructions in 5.2.
2. If it is not properly connected, correct the connection and execute PING with a remote host address in order to verify the proper connection.

### 6.2. Check With Loop Back Address

A loop back address turns back just before the network PCB and returns. Therefore, if you execute PING with this address, you can check whether the TCP/IP settings of a main unit are correct or incorrect.

1. Input the loop back address (127.0.0.1) to PING.
2. If "NG" is indicated, check the TCP/IP settings of a main unit and execute PING again.
3. If "OK" is indicated, follow the instructions in 5.3.

### 6.3. Check With Local Host Address

A local host address is an IP address of a main unit. If you execute PING with this address, the address turns back at the network PCB and returns, so you can check whether the network PCB is non-defective or defective.

1. Input an IP address of a main unit to PING.
2. If "NG" is indicated, follow the instructions below and execute PING again.
  - [1] Incorrect IP address of the machine: Check IP address settings of a main unit, and verify with a system administrator whether or not the assigned IP address is valid.
  - [2] Network PCB connection failure: Check the connection of the connectors on the network PCB.
  - [3] Network PCB failure: Replace the network PCB.
3. If "OK" is indicated, a network environment at the user's site might be a cause. Report the condition to a system administrator and ask him/her to work out a problem.

1. Select RUI-DSP in service mode.  
Service Mode> Copier> OPTION> BODY> RUI-DSP
2. Enter "1" and press the OK key.
3. Press the reset key to exit service mode.
4. Confirm that the remote UI is set ON in the additional functions setting.  
Additional Functions Key> System Setting> Remote UI  
If the remote UI is OFF, turn it ON, then turn off and on the main switch.
5. Ask a system administrator at a user's site to access to the copier from a PC via network.
6. Verify that "Copy," which is for sending copy command from the PC, has been added on the remote UI screen displayed on the PC.

